

Guidelines for the design of safe external rotary milking platforms.

The guidelines are the result of working groups with OSH, NZMPTA, farmers and manufacturers of rotary milking platforms and milking equipment.

In order to identify all risks the rotary platform has been split up into Zones as per page 2. This guideline analyses the risks in the various zones firstly with the platform running in the forward direction, then the reverse direction. Other operations such as herd testing, cleaning and maintenance are also considered. A logical process has been followed to identify all possible risks.

In the guidelines below many references are made to safety stop devices. Larger platforms have longer stopping distances. A safety stop must cause the platform to stop before any injury results. Where stopping distances are a concern the safety stop device shall be situated and activated an appropriate distance ahead of the trapping point. To avoid the safety device becoming a hazard itself, it shall be able to move from the point of activation to the trapping point.

Emergency stops, either button or rope type shall be connected so that power is immediately cut to the platform drive motors. The (electrical) inverter ramp down stop function shall not be used in the emergency situation. Some damage to the platform drive units may be caused if the emergency function is used as an operating stop. The intention is for the emergency stop to be used only in emergency situations. The definition of emergency stop does not extend to include auxiliary braking devices.

If the identified hazards do not exist in any specific installation due to its specific design, then the safety feature described for that general area is also not required. Similarly if hazards identified in these guidelines are introduced by the addition of other systems or components such as washing, cleaning, feedings systems and automation components, compromising the specified safety clearances, then additional modifications shall be introduced to maintain the specified safety clearances.

This guideline benchmarks a standard for the design, manufacture, and installation of external rotary milking platforms. Other designs should consider the safety benchmarks set out in these guidelines.

The guidelines have referred to Anthropometric Data, AS 4024.1-1996 **Safeguarding of machinery** and the OSH publication on "Safeguarding options for Rotary Milking Machines" No.14 April 2001. Some compromises have been made with reference to this OSH publication when setting these guidelines, to enable the design, manufacture and installation of a productive working system.

**Zone 1
Platform Running Forward**

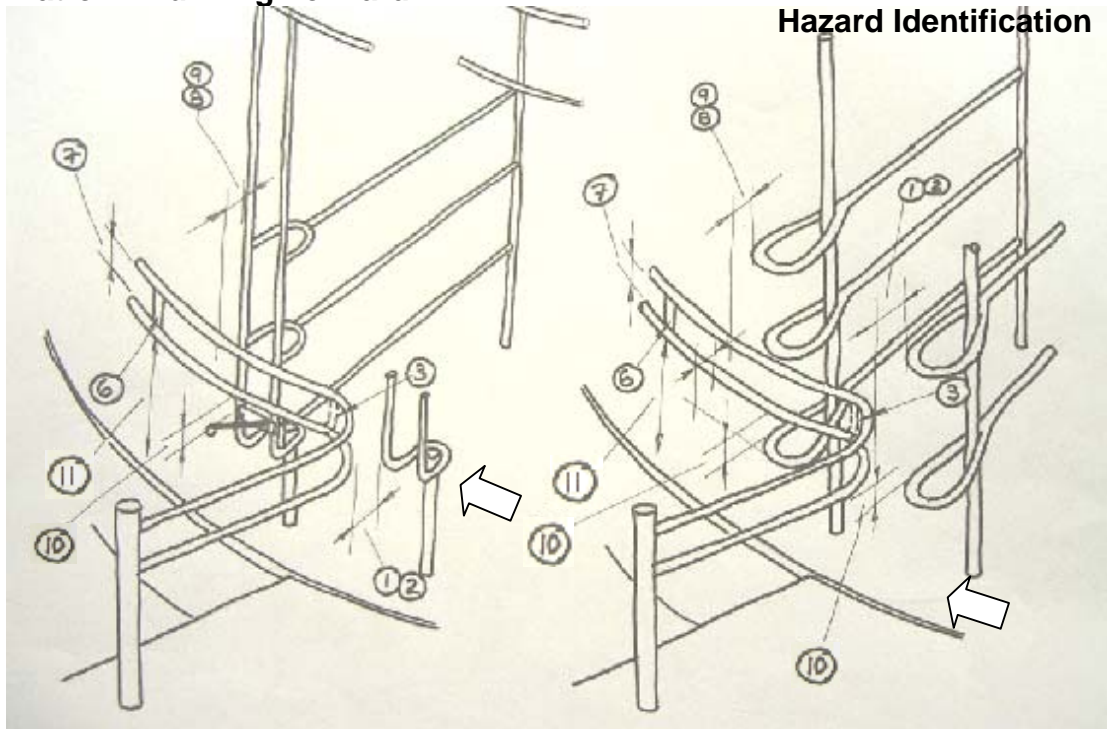

Sketch showing entry area hazards (entry safety switch not shown for clarity)

Key

1. Breech rail at entry
2. Kick rail at entry
3. Kick rail to breech rail connection
6. Vertical connections between kick rail and rump rail
7. Gap between breech rail and kick rail
8. Gap between breech rail and bails
9. Gap between kick rail and bails
10. Vertical gap between breech or kick rail and platform or platform accessories.
11. Kick rail height.



Typical entry safety switch

WORD DEFINITION

Breech (or Rump)Rail: The fixed circular rail behind the cows that keeps the cows from backing off the platform. Extends almost all the way round the platform.

Breech rail support: These are pipes that are mounted in the floor or from the roof at one end, and hold the breech rail up at the other end.

Kick Rail: A fixed circular rail below the breech rail to stop cows kicking.

Bail: This is the pipe that separates the cows on the platform. Generally vertical, between the cows, it moves with the cows.

Platform: The large circular platform on which the cows stand. It has a large hole in the centre and generally rolls on an I-beam. Some rollers are powered.

Platform ribs: These are steel ribs that support the platform. They radiate out to the edge of the platform, underneath the platform.

Bridge: The bridge is an arc of floor the cows walk on to get on and off the platform. It is very close to the platform for 2 to 3 metres and does not move.

Hinged D Gate: This is the small gate that separates cows moving onto the platform from those moving off the platform. Is hinged for safety only. It is mounted in the bridge

Hazard 1: Breech Rail at entry.
Description: Cow and operator trapping point between bail structure and breech rail at entry.
Solution: A breech rail safety switch shall stop the platform. The platform can be manually reversed, forward operation shall be manually initiated again if the pressure switch is released.

Hazard 2: Kick Rail at entry.
Description: Cow and operator trapping point between bail structure (and cup removal mechanism if fitted) and kick rail at entry.
Proposal: The breech rail safety switch shall be able to protect both breech rail and kick rail trapping points. Consider options of twin arm or dual pressure type safety switches.

Hazard 3: Kick rail to breech rail connection at entry.
Description: Operator trapping point between vertical kick rail connection to breech rail and moving bail structure or projections from bails

Proposal:

Ensure that breech rail safety switch described in hazards 1 and 2 shall protect against hazard 3 as well. The kick rail in the entry area shall butt into the same entry support post as the breech rail eliminating the need for a vertical connection to the breech rail at this point. Although many designs use a single switch, separate switch devices are acceptable.



- Ensure that the breech rail and the kick rail are protected by a safety switch or switches.
- Also ensure that the kick rail butts into the same support post in the entry/exit area as the breech rail.
- Also ensure that kick rail connections to rump rail are as specified in hazard 6.

Zone 2 Platform Running Forward

- Hazard 4:** Clearance between platform and parlour walls.
Description: Where the gap between the parlour wall and the platform is too narrow, operators are forced to walk too close to the platform and are at risk of getting kicked.
Proposal: The minimum gap between the parlour wall and the outside edge of the platform or other rotary platform accessories shall be 1100 mm to allow traffic to proceed around the platform.
- Hazard 5:** Kick Rails
Description: Where the kick rail is not continuous and it is restarted, the vertical connection to the breech rail presents a trapping point against the bail structure or any projections from the bail.
Proposal: Full kick rails shall be installed as a standard feature. The kick rail shall be installed continuously around the platform.
- Hazard 6:** Vertical connections between kick rail and rump rail.
Description: Numerous vertical connections between the kick rail and the breech rail present a trapping hazard between the vertical bail structure or bail projections.
Proposal: The number of vertical connections to the breech rail supports shall be restricted to the number of breech rail support posts, a minimum of 3.25 m apart. The kick rail pipe diameter shall be 32 mm to suit above arrangement. Breech rail to kick rail connectors shall be 200 mm away from the stalling.

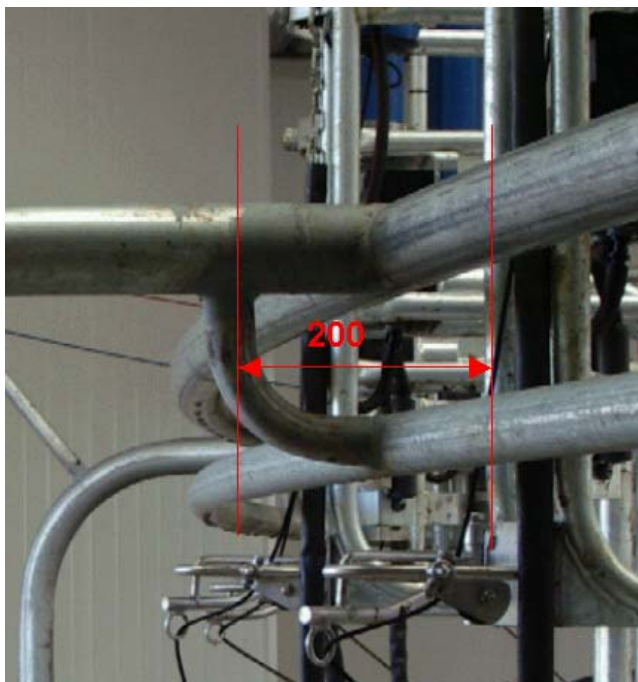

- Hazard 7: Gap between breech rail and kick rail.
 Description: A trapping hazards exists if operator should insert head for any reason through breech rail and kick rail.
 Proposal: The gap between top side of kick rail and underside of breech rail shall be limited to 135 mm to prevent operators putting their heads between these rails. Should this gap exceed 135 mm an intermediate rail/wire(s) shall be installed with a gap between the intermediate rail/wire and the breech or kick rail also not exceeding 135 mm.
- Hazard 8: Gap between breech rail and bails.
 Description: Trapping point between the bail structure and the breech rail.
 Proposal: The gap between the inside face of the breech rail and the bail structure needs to be sufficiently large enough to avoid trapping arms and hands but also needs to be small enough to ensure this does not become a cow trapping point or cow flow disturbance. The inside face of the breech rail shall be 75 mm away from the bail structure. The gap between the kick rail support pipes should also exceed 200 mm at the breech rail level.

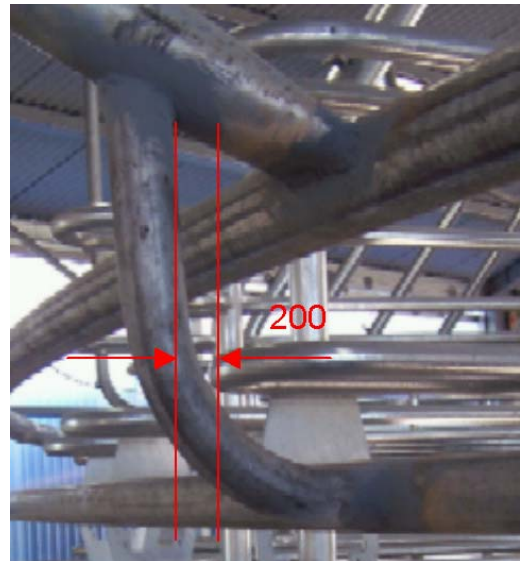
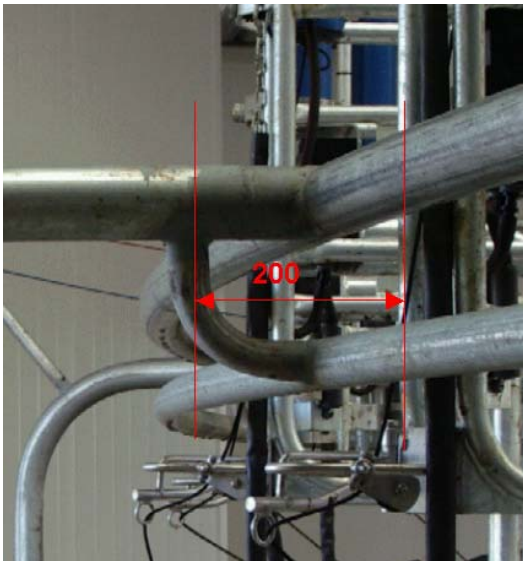

Where a bail is of the “teardrop” design style and rails extend beyond the breech rail, the trapping point at the entry rails shall be protected by a breech rail safety switch in the entry and exit area as described in hazard 1.

Hazard 9: Gap between kick rail and bails.
Description: Trapping point between the bail structure and the kick rail.
Proposal: The gap between the inside face of the kick rail and the bail structure needs to be large enough to avoid trapping arms and hands but also needs to be close enough to be effective as a kick rail. The inside face of the kick rail shall be a minimum of 75 mm away from the bail structure. The gap between the kick rail support pipes should also exceed 200 mm at the kick rail level.

Where a bail is of the “teardrop” design style and rails extend beyond the breech or kick rail, the trapping point at the entry rails needs to be protected by a breech rail safety switch in the entry and exit area as described in hazard 1. (See sketches in hazard 8)

Hazard 10: Vertical gap between the breech or kick rail and platform or platform accessories.
Description: Operator at risk of trapping hands and arms between the breech or kick rail and platform accessories.
Proposal: The gap between the underside face of the breech or kick rail and the top side face of the stall work or any accessory mounted on the platform shall be a minimum of 50 mm. If any such part of the bail or accessories exist protection shall also be provided by a safety switch in the entry and exit area as described in hazard 1.

Hazard 11: Breech rail and kick rail height.
Description: Operators at risk of being kicked if kick rail is not positioned correctly.
Proposal: The breech rail shall be positioned between 800 and 950 mm above the platform. The inside face of the breech rail shall be at the same vertical plane as the inside face of the kick rail.

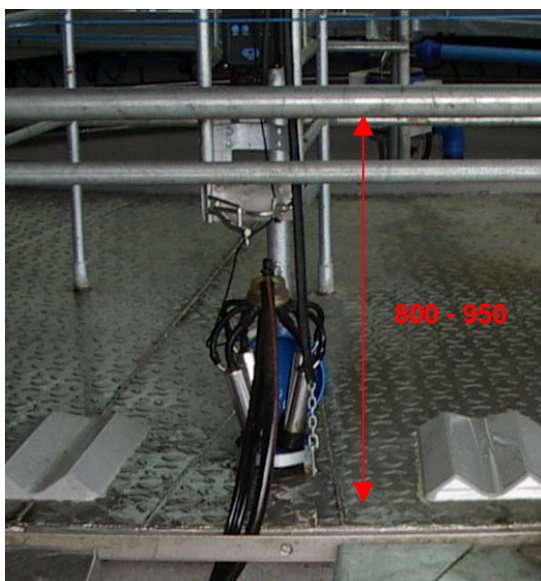

- Hazard 12: Position of vertical floor mounted breech rail post from platform.
- Description: Operators at risk of being trapped between platform and vertical floor mounted breech rail post.
- Proposal: The gap between the platform or the platforms outer most projections and the floor mounted breech rail posts shall be at least 350 mm providing that the gap between the support post and the wall is 750mm or more. Other breech rail post designs that comply with other aspects of the guidelines and are intentionally positioned in excess of 1100 mm away from the platform are also acceptable.
- Hazard 13: Design of roof mounted breech rail support.
- Description: The gap between the vertical roof mount support dropper and the bail structure can present a pinch point. Typically a 45 degree angle is used to connect to the breech rail which encroaches into the required safety space.
- Proposal: The vertical roof mounted support dropper shall be fitted 500 mm away from the bail structure with a 30 to 45 degree bend junction to the breech rail.
- Hazard 14: Platform edge and bridge face at exit
- Description: The gap between the platform edge and the bridge face is a trapping point for exit operators' limbs. This trapping point is aggravated if the platform has ribs that project below the deck.
- Proposal: A safety switch shall be fitted at the bridge face that will stop the platform before any injury to exit operator is caused. A Teflon or rubber protector flap may be an option with certain platform/equipment arrangements. Where the platform has ribs that project down below the outer ring, these projections shall be chamfered back or manufactured with large radius corners. An alternative safety protection is to extend the platform outer ring down below the rib level.
- Hazard 15: Multiple identified and unidentified hazards requiring emergency stop.
- Description: The current rope switches used by most platform manufactures are an operating control device and this switch shall now be supplemented or replaced with an emergency stop rope pull switch. This emergency stop rope pull switch shall also have a reset button that shall be activated before the platform, and can be restarted from the console. The switch shall also be installed as a rapid stop function. This switch shall also be accessible in the entry exit area as it will provide additional safety for operators in this area. In order to reduce costs platforms can be quoted with just the emergency rope safety stop, and the regular stop start rope switch can be quoted as an extra.

Hazard 16:	Slippery platform Deck Surfaces.
Description:	Slipping cows can cause injury to operators or AI technicians etc.
Proposal:	Steel platforms decks shall be made from a suitable tread plate material. Concrete platforms require a hardened and brushed surface. Concrete should be 40 mPa.
Hazard 17	Electrical Shock.
Description:	Control consoles for platform operation are always installed in a wet area. There is a risk of electrical shock.
Proposal:	Control consoles shall operate on 48 volt circuits or less eliminating the risk.
Hazard 18	Platform Speeds.
Description:	Platforms are often run faster than a short milk out time rotation speed when being used for other activities. Platforms are also often rotated a high speed to the cleaning park point to save time. High speed platform operation, especially during non milking activities, poses a greater risk.
Proposal:	The maximum rotation speed shall be limited to the maximum milking speed of the platform.

Zone 3 Platform Running forward.

Hazard 19:	Gap between hinged D-gate and bail structure
Description:	Risk to cow or operator caught in exit area between bails and hinged D-gate.
Proposal:	The D-gate shall be hinged in the forward direction and shall swing open to allow a full 500 mm clearance from bail. The clearance in the closed position shall be a minimum of 75 mm.

Zone 1 Platform Running in Reverse.

Hazard 20:	Gap between D-gate and bail structure
Description:	Risk to cow or operator caught in entry areas between bails and D-gate
Proposal:	The gap between the bail structure and the D-gate shall be no less than 75 mm. A reverse jog switch shall be installed in the platform control console. This switch shall only reverse the platform while the operator is close to this critical area and has his or her finger on the button. This manual function will require operator attention in this area and will minimise the risk.

Zone 2 Platform Running in Reverse.

Hazard 21: Platform edge and bridge face at cow entry.
Description: The gap between the platform edge and the bridge face is a trapping point for operators' limbs. This trapping point is aggravated if the platform has ribs that project below the deck.
Proposal: A reverse jog switch shall be installed in the platform control console. This switch shall only reverse the platform while the operator is close to this critical area and has his or her finger on the button. This manual function will require operator attention in this area and will minimise the risk. A safety interlock may be fitted over the nip area formed by the platform reversing.

Where the platform has ribs that project down below the outer ring, these projections shall be chamfered back or manufactured with large radius corners. Alternatively, the platform outer ring can be extended down below the rib level.

Zone 4: Platform Running in Forward or Reverse.

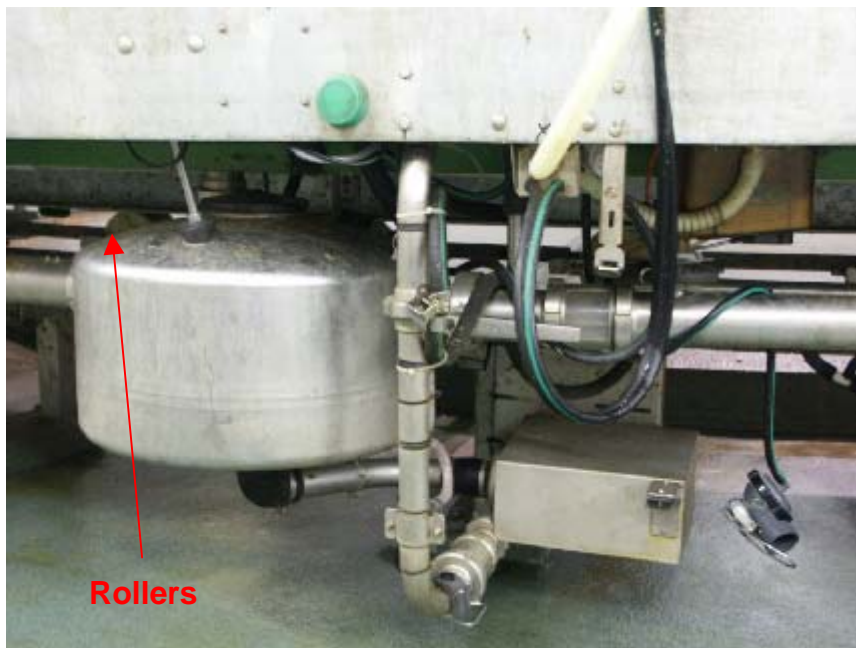

Rollers exposed especially when not hidden by equipment

Picture from outside of rotary without skirt. Note operator is exposed to risk of moving equipment and platform rollers.

- Hazard 22: Protection from platform running gear and other rotating equipment below the platform.
- Description: Operators are exposed to multiple risks if there is any possibility to make contact from the operating area with the running gear or other rotating equipment.
- Proposal: A fixed safety skirt shall be fitted between the underside of the platform deck and the operator floor right around the platform. Safety skirt shall be approximately 0.9 mm thick steel, stainless steel or suitably thick plastic material.
- Hazard 23: Slippery operators floor.
- Description: The operator area around the platform can be slippery and dangerous.
- Proposal: Suitable concrete surfaces and the use of non slip adhesive strips or paint shall be used.

Zone 6: Platform Running in Forward or Reverse.

- Hazard 24: Access to central pit area.
- Description: Safe access is required to central pit area. Access is often provided by a set of steps or ladder fixed to the rotating platform.
- Proposal: Steps/Ladders shall comply with NZ Building Code 1991 - ladders under D1 / AS1 Section 5 Ladders, or Australian Standards AS1657-1992. Steps or ladders that allow the operator to access the pit at 90 degrees to the typical cow position shall be installed so that the operator gets off the platform as it is moving away from him in the forward direction. The specified riser dimension between tread plates may result in a non standard dimension between last step and pit floor. See design code at end of document.
- Hazard 25: Access to central pit through underpass
- Description: People accessing the central pit area through an underpass may find a trapping point when the receiver or other low level equipment passes over the underpass.
- Proposal: An interlocked stop switch and safety gate shall be installed in the underpass. In some installations a fixed cover plate between the moving equipment located above the head of a person using the underpass shall be installed as an alternative solution. Where the underpass and its riser into the central pit area is a suitable depth and distance beyond the rotating equipment, no additional protection may be necessary. See design code at end of document.

Hazard 26:	Risk of moving equipment to operators involved in herd testing
Description:	Exposure to multiple risks when herd testing inside a rotating platform.
Proposal:	An emergency stop or rope emergency stop shall be installed in the central pit herd testing area.
Hazard 27	Injury to maintenance staff in pit area.
Description:	Maintenance staff could be at risk if the platform was inadvertently started by an operator unaware of the maintenance situation.
Proposal:	Lockable isolators shall be fitted to the drive motor installations. These isolators shall be mounted adjacent to the drive motors.
Hazard 28	Access to operators zone from yard.
Description	Operators may slip or fall when moving from the yard to the operators zone.
Proposal	Standard steps with high grip edge and hand rails to limit chance of slipping. See design code at end of document.
Hazard 29	Platform control
Description	Platform control panels with equal functionality at attach and detach positions can expose operators to platform movement risks.
Proposal	The attach operator console shall always be the master control console and shall be the only console with a reverse switch.

Zone 8 Collecting Yard.

Hazard 30:	Crowd gate drive wheels.
Description:	There is a risk that operators' hands may be pinched between crowd gate drive wheels and running rails on top of yard fence.
Proposal:	Crowd gate wheels shall be guarded.
Hazard 31:	Crowd gate falls off rails.
Description:	There is a risk that operators and cows can be injured by crowd gates which are knocked off, or fall off the running rail.
Proposal:	Crowd gates shall be fitted with a retaining device so that the gate cannot come off the top rail unless deliberately removed.

Hazard 32
Description: Gate in crowd gate top rail.
There is a risk that crowd gates can fall off the top rail should a gate forming an integral part of the running rail be opened while the crowd gate is in operation.
Proposal: An electrical or mechanical stop device shall be provided at either side of the gate opening. An alternative could be to provide a running rail at a higher level so that gate movements do not break the crowd gate running rail.

Hazard 33:
Description: Yard fence and end of crowd gate.
Risk of injury due to crushing by crowd gates at front and rear of yard and between two crowd gates.
Proposal: An automatic stop device for each of the above situations shall be provided where operator crushing is possible. Suitable protection shall also be provided for water driven crowd gates.

All Zones.

Hazard 34
Description: Limited safety signage alerts.
All identified risks require safety alert signage
Proposal: A safety sign package shall be provided with the platform. Comment shall be made on signs that safety gaps are designed for adults, and children are not necessarily protected.

Operators' manual shall include a safety chapter.
A wall chart of basic safety precautions shall be installed near the operator. This chapter shall include instruction on restricted milking parlour access, and off limit areas for visitors and children.

Hazard 35
Description: Exposure to sumps and drains
Operator and others are exposed to contamination and drowning risks from sump and drain contents.
Proposal: All drains shall be provided with secure drain and sump covers

Breech Rail fixing options and critical dimensions

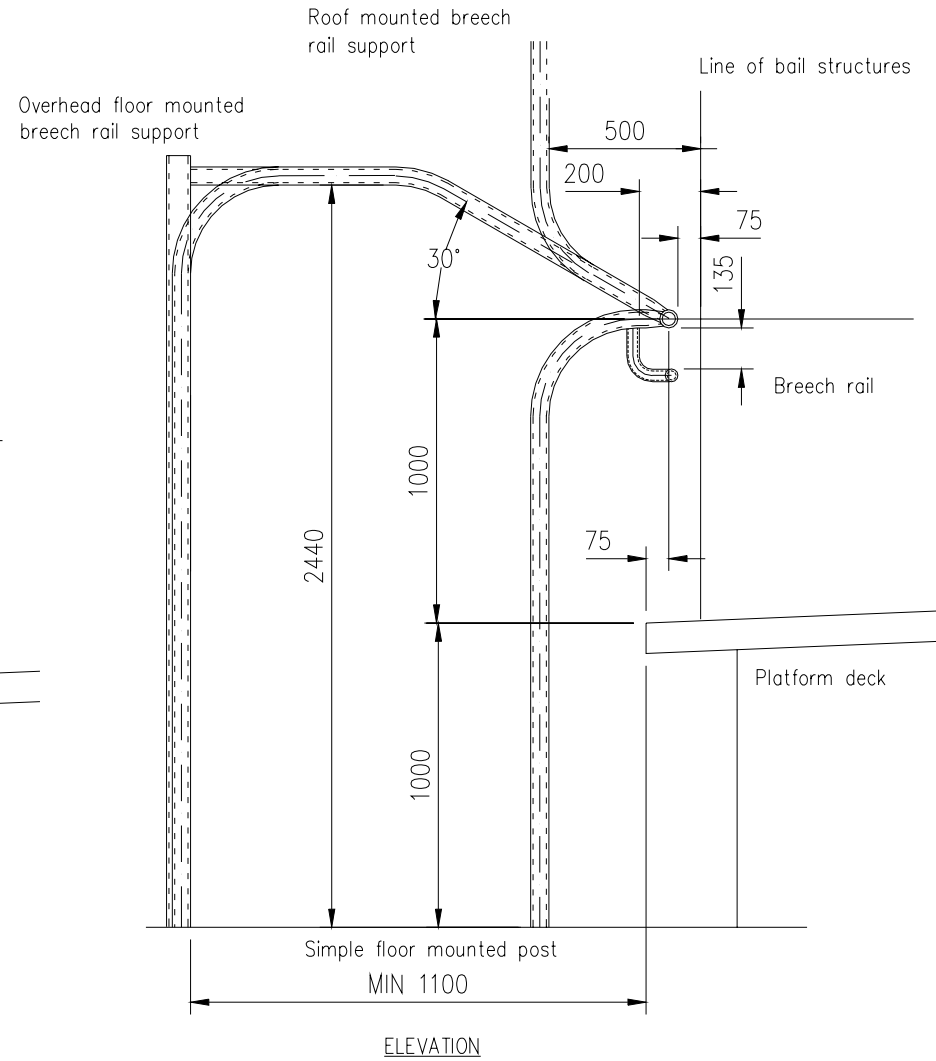
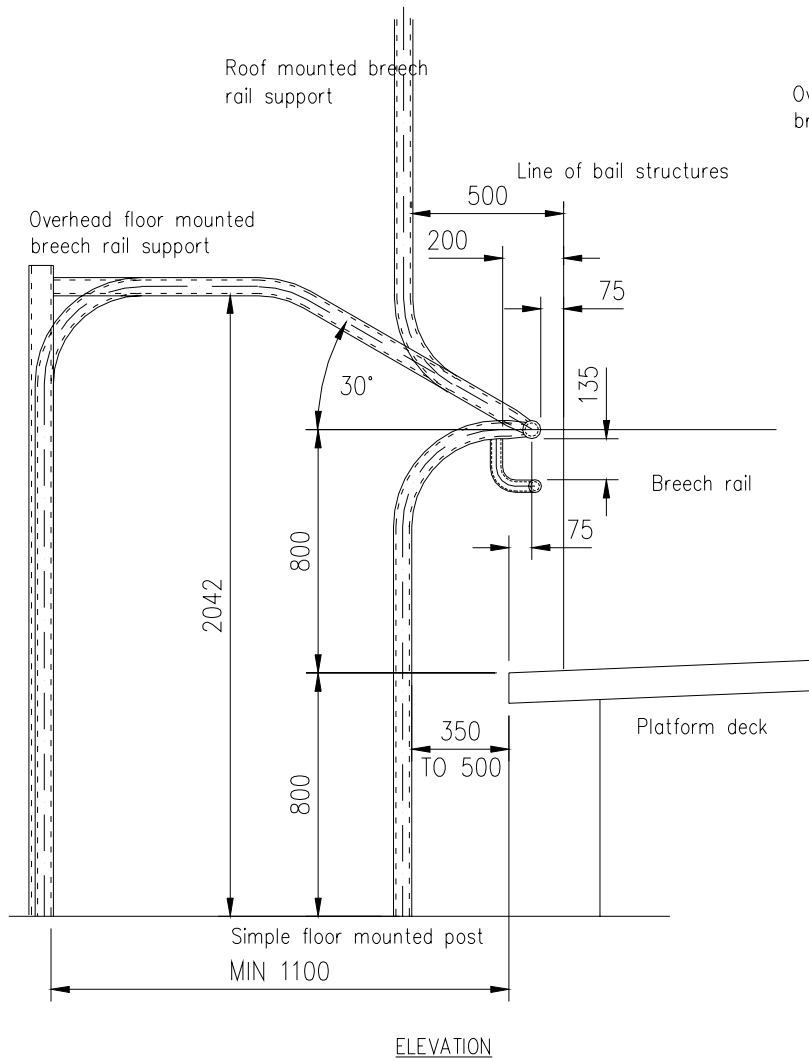

Hazard Identification Zone References

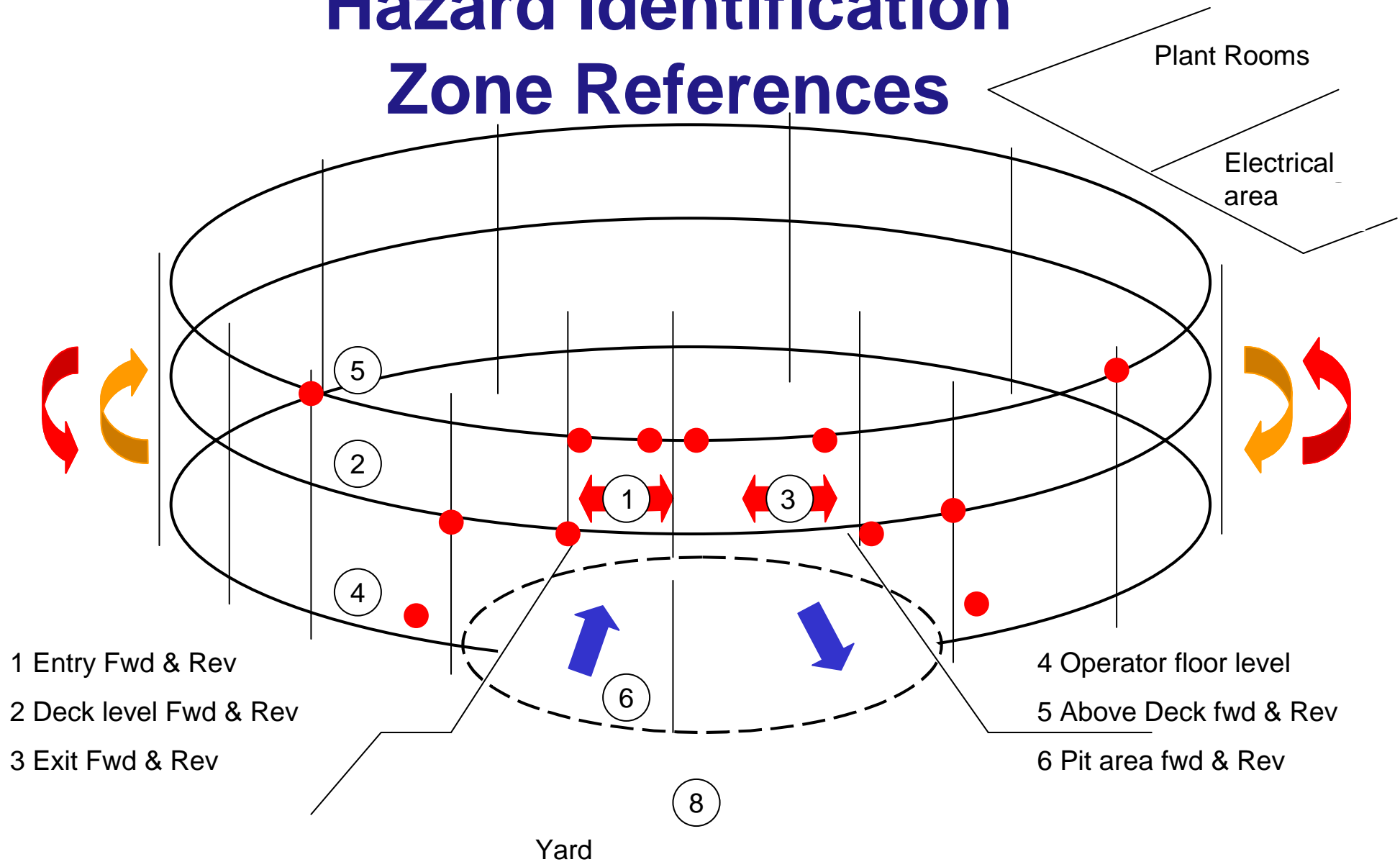

Stairways

Treads and risers on any stairway must be of uniform dimensions. The rise of each tread and the going (depth) will be governed by available space but shall comply with the following criteria:

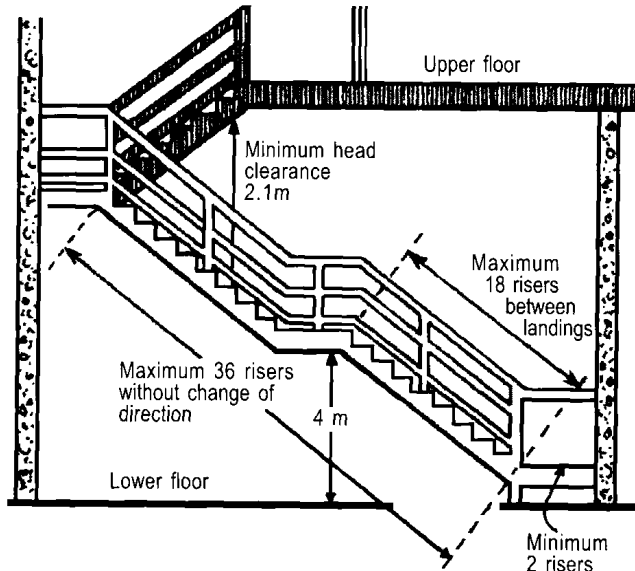

- The pitch of the stair should be between 30°- 50° from the horizontal.
- The height of the rise and depth of the going of each step should approximate the formula, 'twice the rise plus the going equals 600 mm' e.g. rise of 160 mm, going of 280 mm, $2 \times 160 + 280 = 600$

The maximum number of stairs between the landings should be 18, with no more than two flights without change of direction.

The depth of any landing should be at least equal to the stair.

Guard rails shall be provided on the open side of all stairs. Handrails must be provided on one side of all closed stairs. Stairways wider than 1 metre shall have hand or guardrails on each side.

The nosing of each tread should extend 25 mm over the riser and be of a non slip material.

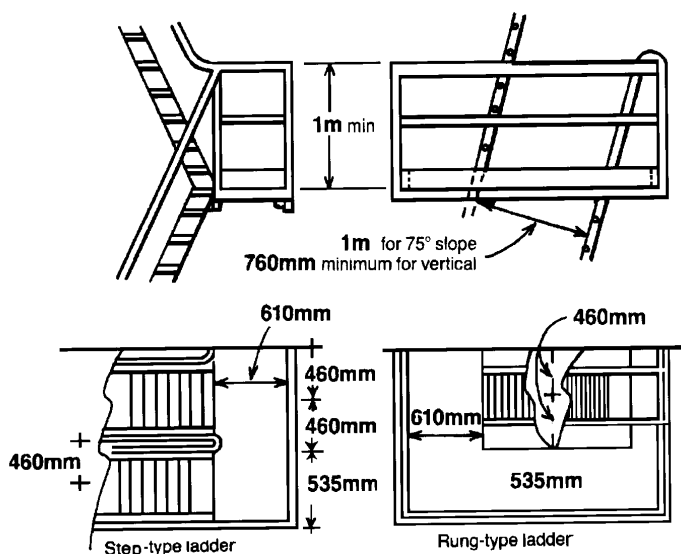

Service stairs around plant or machinery, etc. may not be able to meet these criteria, but every effort should be made to do so.

Failing this they should be built to the dimensions and pitch of a step or tread ladder.

Spiral stairways should be avoided if at all possible.

Fixed Tread or Step Ladders

These ladders should be pitched at an angle of 60° - 70°. Treads should be at least 100 mm wide, with a rise of between 200 – 250 mm.

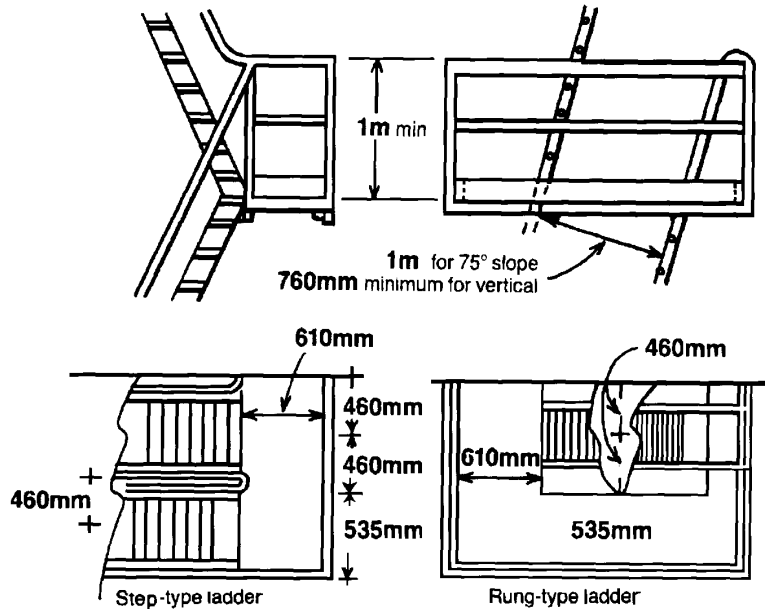

Guardrails should be fitted at a minimum height of 0.9 metres vertically above the nosing of the treads. Other requirements include:

- Maximum length of 6.1.m
- Minimum width of 460 mm with the distance between guard rails of 535 – 760 mm.

Fixed Rung Ladders

Rung ladders should be pitched between 60° - 70°. The rungs should be 250 – 300 mm apart with a width of 400 mm. Other requirements include:

- A clear distance of 150 mm behind the ladder.
- All ladders above 6 metres in height and steeper than 75° shall be fitted cage guards or hoops and straps from 2.5 metres in height.
- All ladders stiles should extend 1 metre above the step off point unless suitable hand holds are provided.
- Reverse climbing ladders shall have a clearance of 760 mm between the ladder and the structure.
- The maximum length of a vertical fixed ladder between landings should be 9 metres.

Examples of Safety Signage

Good quality signs shall be placed at all risk points and not necessarily limited to the examples below.



All parlour entries shall display clear warning signs



People in the pit to be alerted to possible risks.



Warning signs required at pinch points between platform and bridge.



Operation warnings on consoles and in office areas.